



# 16X Max IDE CD-ROM Drive

---

*User's Guide*

OPTIONS  
*by IBM*

**Note:** If you are using this product in the United States, Canada, or Puerto Rico, be sure to read the information under “Product Warranty” on page 3-18 before using this information and the product it supports.

*For all other countries, the warranty terms and conditions applicable in the country of purchase are available from IBM or your reseller.*

#### **First Edition (March 1997)**

**The following paragraph does not apply to the United Kingdom or any country where such provisions are inconsistent with local law:** INTERNATIONAL BUSINESS MACHINES CORPORATION PROVIDES THIS PUBLICATION “AS IS” WITHOUT WARRANTY OF ANY KIND, EITHER EXPRESS OR IMPLIED, INCLUDING, BUT NOT LIMITED TO, THE IMPLIED WARRANTIES OF MERCHANTABILITY OR FITNESS FOR A PARTICULAR PURPOSE. Some states do not allow disclaimer of express or implied warranties in certain transactions, therefore, this statement may not apply to you.

This publication could include technical inaccuracies or typographical errors. Changes are periodically made to the information herein; these changes will be incorporated in new editions of the publication. IBM may make improvements and/or changes in the product(s) and/or the program(s) described in this publication at any time.

This publication was produced in the United States of America. IBM may not offer the products, services, or features discussed in this document in other countries, and the information is subject to change without notice. Consult your local IBM representative for information on the products, services, and features available in your area.

Requests for technical information about IBM products should be made to your IBM reseller or IBM marketing representative.

© Copyright International Business Machines Corporation 1997. All rights reserved.

Note to U.S. Government Users — Documentation related to restricted rights — Use, duplication or disclosure is subject to restrictions set forth in GSA ADP Schedule Contract with IBM Corp.

## Contents

<b>Safety: Read First</b> . . . . .	v
<b>About This Book</b> . . . . .	vi

---

<b>Part 1: Quick Installation Guide</b> . . . . .	1-1
---	-----

---

<b>Part 2: User's Guide</b> . . . . .	2-1
---------------------------------------	-----

<b>Product Description</b> . . . . .	2-1	<b>Preparing the Drive for Use</b> . . . . .	2-9
Front View of the Drive . . . . .	2-2	Installing Windows 95 Support Software . . . . .	2-9
Back View of the Drive . . . . .	2-2	Installing DOS with Windows Support Software . . . . .	2-9
<b>Before You Begin</b> . . . . .	2-3	Installing OS/2 Support Software . . . . .	2-10
Installation Requirements . . . . .	2-3	Using Fast Setup for Dual-Boot OS/2 Warp and Windows . . . . .	2-11
Device Handling Precautions . . . . .	2-5	<b>Using the Drive</b> . . . . .	2-12
<b>Installing the Drive</b> . . . . .	2-5	Handling a CD . . . . .	2-12
Step 1. Opening Your Computer . . . . .	2-5	Loading a CD . . . . .	2-12
Step 2. Unpacking the Drive . . . . .	2-5	Manually Ejecting a CD . . . . .	2-14
Step 3. Determine the IDE Port and Device Jumper Settings . . . . .	2-6	Playing an Audio CD . . . . .	2-14
Step 4. Setting the Configuration Jumper . . . . .	2-6	Using a Data CD . . . . .	2-16
Step 5. Mounting the Drive in the Bay . . . . .	2-7	<b>Solving Problems</b> . . . . .	2-17
Step 6. Attaching the Cables to the Drive . . . . .	2-7	Diagnostics . . . . .	2-22
Step 7. Completing the Hardware Installation . . . . .	2-8	Additional Help . . . . .	2-22
Step 8. Updating the Configuration . . . . .	2-8		

---

<b>Part 3: Appendixes</b> . . . . .	3-1		
<b>Appendix A. Safety Information</b> . . . . .	3-1	<b>Appendix E. Warranty and Notices</b> . . . . .	3-18
<b>Appendix B. Device Driver Configuration Settings</b> . . . . .	3-11	Product Warranty . . . . .	3-18
DOS with Windows Software . . . . .	3-11	System Programs License Agreement . . . . .	3-21
OS/2 Software . . . . .	3-15	Notices . . . . .	3-22
<b>Appendix C. Hard Disk Drive Manufacturers</b> . . . . .	3-17	Trademarks . . . . .	3-23
<b>Appendix D. Technical Support</b> . . . . .	3-17	Electronic Emission Notices . . . . .	3-23
Step 1. Preparing for the Call . . . . .	3-17		
Step 2. Placing the Call to IBM . . . . .	3-18		

## ***About This Book***

This manual contains information on the IBM 16X MAX IDE CD-ROM Drive. The manual is divided into the following parts:

**Part 1:** Abbreviated installation instructions in the following languages:

- English
- German
- French
- Spanish
- Japanese
- Italian
- Brazilian Portuguese

**Part 2:** Product description, installation, usage, and problem solving information

**Part 3:** Safety information, technical support information, warranty, and notices

<p><b>Note:</b> The illustrations in this manual might be slightly different from your hardware.</p>
--

---

## Part 1: Quick Installation Guide

---

The IBM 16X MAX IDE CD-ROM Drive can read a compact disc (CD) containing approximately 680 MB of information (MB equals 1 000 000 bytes). The drive delivers data up to 16 times the standard CD-ROM speed.

The CD-ROM drive is designed for installation in a personal computer that uses the integrated drive electronics (IDE) or the enhanced IDE architecture. For more detailed installation instructions, go to "Part 2: User's Guide" on page 2-1.



**Caution:** Read the Safety Information in Appendix, page 3-1, before installing this product.

In addition to this book, the option (option number 76H6110) includes:

- IBM 16X MAX IDE CD-ROM Drive
- Two audio cables
- Four mounting screws (M3 x 5 mm, slotted)
- *IBM 16X MAX IDE CD-ROM Drive Option Diskette*
- IDE cable for connecting two IDE devices
- Laser Safety Guide for CD-ROMs

Contact your place of purchase if an item is missing or damaged. Be sure to retain your proof of purchase. It might be required to receive warranty service.

---

### Installing the Drive

---

1. Turn off all attached devices. Turn off the computer. Unplug the power cords for the computer and all attached devices; then open the computer.
2. Before opening the static-protective bag containing the drive, touch the bag to an unpainted metal surface on the computer for at least two seconds. Remove the drive from the bag.
3. Newer computers typically have two IDE ports. If your computer has two IDE ports, use the secondary IDE port to connect the CD-ROM drive. Typically the secondary IDE port is adjacent to the primary IDE port that connects to your hard disk drive. Based on which IDE port you use and if there is another device on the port, determine the configuration jumper setting for the drive.
  - If you have two IDE ports, connect the CD-ROM drive on the secondary IDE port. If the CD-ROM drive is the only device on the IDE port, configure it as master. If the CD-ROM drive is the second drive on the port configure it as slave.
  - If you must attach the CD-ROM drive on the same IDE port with a faster device like a hard disk drive, configure the

CD-ROM drive as the slave and the hard disk drive as the master (or master with slave present).

- Some non-IBM computers support the cable-select setting, where the position of the device on the cable determines whether a device is master or slave.

4. Set the configuration jumper.

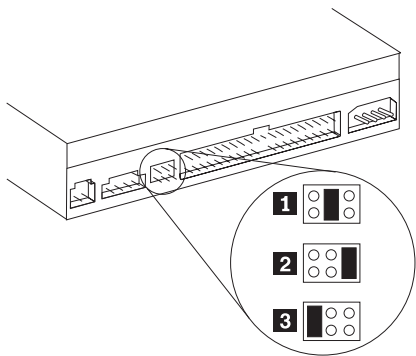

Configure the CD-ROM drive by placing one jumper over a set of configuration pins.

- If you are configuring the driver as master, set the jumper to the master **2** device setting. (Master is the factory-shipped setting.) If there is a second device on the IDE port, check that the device is configured as slave.
- If you are configuring the drive as slave, set the jumper to the slave **1** device setting. Check that the other device on

the IDE port is configured as master (or master with slave present).

- If you are configuring the drive as cable select, set the jumper to the cable-select **3** device setting. If there is another device on the IDE port, check that the device is also configured for cable select.

5. Mount the drive horizontally or vertically into the bay in the computer; secure the drive with the mounting screws.

6. Connect the cables to the CD-ROM drive as follows:

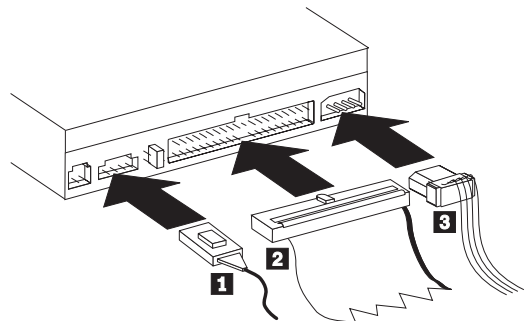

- Attach a 40-pin IDE-cable connector **2** to the device IDE connector. Align the cable so that the color-coded edge is closest to the power cable connector **3**. Use the IDE cable provided with this option if there is no cable attached to the IDE port or there is only one device connector on the IDE cable.

- Attach a four-pin power-cable connector **3** to the device dc-power connector.
  - If you have a sound adapter, connect one of the audio cable connectors **1** to the device audio-out connector. Use the audio cable that has a connector that fits your sound adapter and save the other cable in case you use a different sound adapter in the future.
7. Replace the computer cover and secure it. Connect other device cables, as needed. Plug all power cords into electrical outlets.
  8. Update your computer configuration. Because you changed the hardware, the configuration-setup information screen should display. If the screen does not display, see your computer documentation for information about accessing the configuration-setup. For most IBM computers, press **F1** during startup when the graphic displays in the upper right corner of the screen to see the configuration information. When you have finished reviewing the information, save the changes and exit.

**Note:** Some older computers with one IDE port might not detect that the CD-ROM drive is attached to your computer when you review the configuration-setup information. You still can use the CD-ROM drive in this situation as long as you have properly completed the installation.

---

## Preparing the Drive for Use

This section contains the instructions for installing device drivers for the CD-ROM drive, based on the operating system you are using.

If you are using Microsoft Windows 95:

1. Click on **Start** from the main screen.
2. Select **Settings**; click on **Control Panel**.
3. From the Control Panel, double-click on **Add/Remove Hardware**.
4. Click on **Next** and follow the instructions on the screen.

If you are using DOS or DOS with Windows 3.x:

1. Insert the Option Diskette into drive A; open a DOS window.
2. At the DOS prompt, type **A:UINSTALL** and press **Enter**. Follow the instructions on the screen.
3. At the Installation Options menu, select **Install IDE CD-ROM DOS with Windows Support Software** and press **Enter**.
4. Follow the instructions on the screen.

**Note:** If you need options that are not found in the UINSTALL device driver installation program to resolve resource conflicts, refer to the READ.ME file on the Option Diskette. If you have problems installing the software, refer to the UINSTALL program help information.



If you are using OS/2:

1. From the OS/2 Desktop, select the **OS/2 System** folder. Select **System Setup**; then select **Selective Install**.
2. The System Configuration menu is displayed. Select the **CD-ROM Device Support** option. If you are using OS/2 2.1, select **OK**. For other OS/2 versions, follow the instructions on the screen.
3. You are presented a list of CD-ROM devices. Select **OTHER** from the list; then select **OK**.
4. When the System Configuration menu is displayed again, select **OK**. Follow the instructions on the screen.
5. Select **Install** from the OS/2 Setup and Installation screen.
6. The Source Directory screen is displayed. If OS/2 was not preinstalled on your computer, you might need to insert your installation diskettes into the specified drive. Select **Install**, and follow the instructions on the screen.
7. From the OS/2 Setup and Installation screen, select **OK**. *Do not* shut down and restart your system.
8. Insert the Option Diskette into your diskette drive.
9. From the System Setup folder, select **Device Driver Install**; select **Install** at the OS/2 Device Driver Installation screen.
10. At the Select Device Drivers screen, select your drivers from one of the screen options. Select **OK**; then select **Exit** and follow the instructions on the screen.

If you are using an IBM PC 350, 700, or 750 computer (Model 6576, 6577, 6586, or 6887) with Dual-Boot OS/2 Warp and DOS with Windows factory-installed, you can use Fast Setup as follows:

1. Insert the Option Diskette into drive A; then open a DOS window.
2. At the DOS prompt, type **A:CDSETUP2** and press **Enter**.
3. Follow the instructions on the screen.
4. Press **F3** to exit from the CDSETUP2 program.
5. Remove the diskette from drive A; shut down and then restart the computer.

---

## Part 2: User's Guide

### *Product Description*

The IBM 16X MAX IDE CD-ROM Drive can read a compact disc (CD) containing approximately 680 MB<sup>1</sup> of information. It is designed for installation in a personal computer that uses the integrated drive electronics (IDE) or the enhanced IDE architecture.

The CD-ROM drive delivers data up to 16 times the standard CD-ROM speed, delivering data at up to 2400 KB<sup>1</sup> per second. The drive reads compact discs meeting the ISO-9660 and High-Sierra Group (HSG) standards. It also reads multiple-session, extended architecture (XA) discs, such as the Kodak Photo CD.

In addition to this book, the option (option number 76H6110) includes:

- IBM 16X MAX IDE CD-ROM Drive
- Two audio cables
- Four mounting screws (M3 x 5 mm, slotted)
- *16X MAX IDE CD-ROM Drive Option Diskette*
- IDE cable for connecting two IDE devices
- Laser Safety Guide for CD-ROMs

**Important:** Be sure to retain your proof of purchase. It might be required to receive warranty service.

The Option Diskette includes installation and support programs such as:

- Installation programs for DOS, Windows, and OS/2
- IDE CD-ROM device drivers
- Audio CD-player programs
- READ.ME file with additional installation information
- Diagnostic programs

Contact your place of purchase if an item is missing or damaged.

You can find information on how to get help, technical support, and warranty service in Appendix D, "Technical Support" on page 3-17.

---

<sup>1</sup> MB equals approximately 1 000 000 bytes.

---

## Front View of the Drive

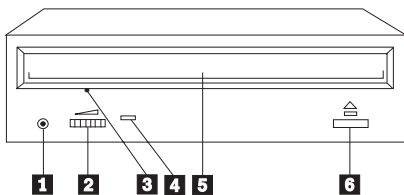

### 1 Headphone Jack

Provides the audio output for headphones

### 2 Volume Control

Controls the audio output volume

### 3 Manual-eject hole

Provides access to the manual eject mechanism to remove a CD from the drive

### 4 Busy indicator

Lights when the drive reads a data CD or plays an audio CD

### 5 CD tray

Loads and unloads a CD

### 6 Eject/Load button

Opens and closes the CD tray

---

## Back View of the Drive

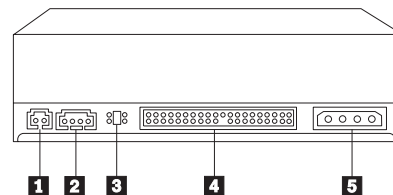

### 1 Reserved

### 2 Audio-out connector

Connects the analog audio signals to a sound adapter  
(The four pins on the audio-out connector (pin out) from left to right are right-ground-ground-left.)

### 3 Configuration pins

Sets the drive configuration

### 4 IDE connector

Connects the CD-ROM drive to the IDE cable

### 5 DC power connector

Connects the dc power cord to the CD-ROM drive

## Before You Begin

Read the following information before you start your installation. If you do not understand these procedures, or are unsure about your ability to perform all the procedures described, have a qualified computer technician install the CD-ROM drive for you, or call an IBM technical support representative.

---

### Installation Requirements

To install the CD-ROM drive you must have:

#### Documentation

You might need the documentation that comes with your computer, operating system, or IDE bus adapter if it is separate from the computer.

#### Minimum Processor

- IBM personal computer or compatible with an 80386 processor (or later version).
- 640 KB<sup>2</sup> RAM (Random-Access Memory) for DOS 3.3 (or later) and 4 MB RAM for Windows 3.1 (or later).
- 3.5 inch 1.44 MB or 2.88 MB diskette drive

#### IDE port and cable

The CD-ROM drive requires an IDE interface to your computer.

- The IDE port is on the system board of the computer or on an IDE bus adapter. Newer computers have two IDE ports on the system board typically adjacent to one another. The primary IDE port should connect to your hard disk drive. (If the interface cable connector has 40 pins, your computer uses the IDE architecture.)
  - If your computer has one IDE port, you can attach up to two devices.
  - If your computer has a primary and a secondary IDE port, you can attach up to two devices on each port for a total of four devices.

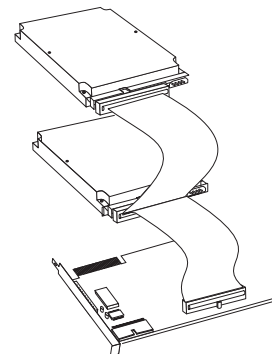

---

<sup>2</sup> For RAM processor storage, KB equals 1 024 bytes and MB equals 1 048 576 bytes.

For most computers, you can attach a maximum of two devices on the IDE cable.

If you have a sound adapter installed, the adapter might have an IDE connector that you can use to attach the CD-ROM drive.

- The CD-ROM drive connection requires an available connector on the IDE cable.
  - If the computer has two IDE ports, examine the cable on both ports for an available connector.
  - Examine the cable attached to the IDE port. If the IDE cable supports the attachment of only one device, you can replace the cable with the one provided with this CD-ROM drive (to provide a second IDE connector).

If you have more than one IDE port, attach hard disk drives to the cable on the primary IDE port. Attach slower devices, such as CD-ROM and tape drives, to the cable on the secondary port. Some computers come with a dual-port, high-performance IDE controller. Connecting the CD-ROM drive to the secondary IDE port provides better operating system performance.

Check the user's guide for any device that will be connected to the same port as the CD-ROM drive; some devices, such as a high speed tape drive, must not be installed on the same port as a CD-ROM drive.

#### **Power connector**

To provide power to the CD-ROM drive, you need an unused 4-pin dc-power connector on the cable coming from the computer power supply. If all power cables are in use, purchase a dc Y-connector (available at most electronic stores) and split a connection to add a power connector.

#### **CD-ROM drive mounting**

The CD-ROM drive installs in an accessible vertical or horizontal 5.25-inch mounting bay. You might need both a flat-blade and a Phillips-head screwdriver for the installation.

#### **Operating system**

The installation instructions are written for the following operating systems.

- Microsoft Windows 3.3 or later (DOS 3.3 or later)
- Windows 95
- OS/2 2.1 or later

#### **PS/2 software**

If you are installing the CD-ROM drive in an IBM PS/2 computer, you might need current copies of the Reference Diskette and Diagnostic Diskette for your computer.

---

## Device Handling Precautions

To protect your CD-ROM drive during installation, observe the following precautions.

- Handle the drive with care. Dropping or jarring the drive can damage the components inside the drive housing.
- Keep the CD-ROM drive in its antistatic bag until you are ready to install the drive in your computer. Limit your movement. Movement can cause static electricity buildup.

To protect your CD-ROM drive during operation, observe the following precautions.

- To avoid damage to the drive and disc, remove any CD in the drive before moving the drive.
- Do not operate the drive under any of the following conditions:
  - High temperature, high humidity, or direct sunlight
  - Excessive vibration, sudden shock, or inclined surface
  - Excessive dust
- To protect the drive:
  - Do not insert foreign objects into the drive.
  - Do not stack objects on the drive.
  - Do not remove the drive cover or attempt to service the drive.

## *Installing the Drive*

Follow these steps to install the CD-ROM drive.

---

### Step 1. Opening Your Computer

Turn off the computer and unplug the cables from the power outlets for your computer and all attached devices. Remove the computer cover. For more information, see the documentation that comes with the computer.

---

### Step 2. Unpacking the Drive

Use the following procedure to unpack and handle the drive.

1. Touch the antistatic bag containing the drive to an unpainted metal surface on the computer for two seconds. This drains static electricity from the bag and your body.
2. Remove the drive from the antistatic bag. If you must put the drive down, place the antistatic bag on a flat padded surface, such as a magazine, and place the drive on the bag with the component side facing up.

---

### Step 3. Determine the IDE Port and Device Jumper Settings

Newer computers typically have two IDE ports. If your computer has two IDE ports, use the secondary IDE port to connect the CD-ROM drive. Typically the secondary IDE port (*SEC IDE*) is adjacent to the primary IDE port that connects to your hard disk drive. You can use the IDE cable provided in the option to connect the CD-ROM drive.

On each IDE port, only one device can be configured as master and one configured as slave. Based on which IDE port you use and if there is another device on the port, determine the configuration jumper setting for the drive.

- If there is only one device on the IDE port, configure the CD-ROM drive as master.
- If you must attach the CD-ROM drive to the same IDE port with a faster device like a hard disk drive, configure the CD-ROM drive as the slave and the hard disk drive as the master (or master with slave present).
- Some non-IBM computers support the cable-select setting, where the position of the device on the cable determines whether a device is master or slave. Check your computer documentation to determine if your computer uses cable select. When using cable select, configure all devices connected to the IDE port to cable select.

---

### Step 4. Setting the Configuration Jumper

Configure the CD-ROM drive by setting the jumper.

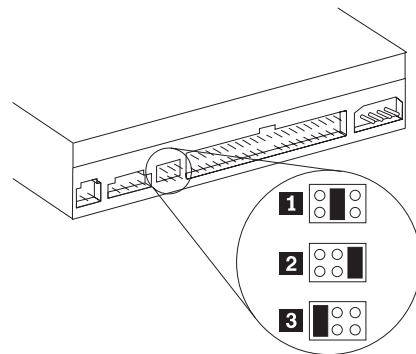

Configure the CD-ROM drive by placing one jumper over a set of configuration pins.

- If you are configuring the drive as master, set the jumper to the master **2** device setting. (Master is the factory-shipped setting.) If there is a second device on the IDE port, check that the device is configured as slave.
- If you are configuring the drive as slave, set the jumper to the slave **1** device setting. Check that the other device on the IDE port is configured as master (or master with slave present).
- If you are configuring the drive as cable select, set the jumper to the cable-select **3** device setting. If there is another device on

the IDE port, check that the device is also configured for cable select.

If you need assistance in setting the configuration jumpers or need additional information about the hard disk drive on the same IDE port as the CD-ROM drive, refer to Appendix C, “Hard Disk Drive Manufacturers” on page 3-17.

**Attention:** Be sure to use the M3 x 5 mm mounting screws in the option package when you are driving screws directly into the drive. Using screws that are too long can damage the drive.

### Step 5. Mounting the Drive in the Bay

Mount the CD-ROM drive horizontally or vertically in the computer.

1. Slide the drive into the bay.
2. Align the drive bay screw holes with the threaded holes in the drive-housing or mounting bracket. Be sure to use the M3 x 5 mm mounting screws provided with this option. Using the wrong size screws might damage the drive.
3. Thread the screws in lightly to secure the drive in the bay. Usually two screws are used on each side. Check the alignment and tighten the screws to secure the drive. *Do not over tighten.*

### Step 6. Attaching the Cables to the Drive

Connect the cables to the CD-ROM drive as follows:

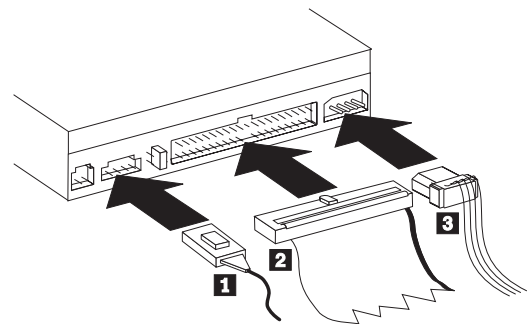

1. If you have a primary or secondary IDE port in your computer, attach the CD-ROM drive to the cable on the secondary port. Use the IDE cable provided with the option if there is no cable connected to the secondary IDE port. Attach the 40-pin IDE-cable connector **2** to the device IDE connector. Align the cable so that the color-coded edge is closest to the power cable connector **3**. The connector on the IDE cable you use to connect the CD-ROM drive does not depend on whether the device is configured as master or slave.

For best results if there are three connectors on the IDE cable, attach the connector at one end of the cable to the IDE port and the other end connector to the CD-ROM drive. You can leave the middle connector open.



2. Attach the four-pin power-cable connector **3** to the device dc-power connector. The cable connector is keyed and will fit easily only one way. Do not force it. If it does not attach easily, turn the connector around and try it again.
3. If you have a sound adapter, connect one of the audio cable connectors **1** to the device audio-out connector.

There are two audio cables with the option. One cable has identical connectors at both ends. The second audio cable has a narrower connector at one end to fit some sound adapter connectors. Use the audio cable that has a connector that fits your sound adapter, and save the other cable in case you re-install the CD-ROM with a different sound card.

---

## Step 7. Completing the Hardware Installation

To complete the hardware section of the CD-ROM drive installation:

- Be sure that the drive is securely mounted and the connectors are firmly attached.
- Be sure the cables do not interfere with the computer cover and do not block the power-supply fan blades or air-flow paths.
- Reinstall the computer cover.
- Reconnect all devices and check any devices that might have become undone, such as the keyboard, mouse, and monitor.
- Plug all power cords into electrical outlets.

---

## Step 8. Updating the Configuration

Because you changed the hardware in your computer, the configuration-setup information screen should display. If the screen does not display, see your computer documentation for information about accessing the configuration-setup. For most IBM computers, press **F1** during startup when the graphic displays in the upper right corner of the screen to see the configuration information. When you have finished reviewing the information, save the changes and exit.

**Note:** Some older computers with one IDE port might not detect that the CD-ROM drive attached to your computer when you view the configuration-setup information. You still can use the CD-ROM drive in this situation as long as you have properly completed the installation.

## *Preparing the Drive for Use*

This section contains the instructions for installing device drivers for the CD-ROM drive, based on the operating system you are using.

- If you are using Windows 95, go to “Installing Windows 95 Support Software.”
- If you are using DOS or DOS with Microsoft Windows 3.x, continue with “Installing DOS with Windows Support Software.”
- If you are using OS/2, go to “Installing OS/2 Support Software” on page 2-10.
- If you are using an IBM PC 350, 700, or 750 computer (Model 6576, 6577, 6586, or 6887) with Dual-Boot OS/2 Warp and DOS with Windows factory-installed, continue with “Using Fast Setup for Dual-Boot OS/2 Warp and Windows” on page 2-11.
- If you are using another operating system, see the documentation that comes with your computer and operating system. Then, go to “Using the Drive” on page 2-12.

---

## **Installing Windows 95 Support Software**

This section contains the instructions for installing device drivers and support software for the CD-ROM drive in computers running Windows 95.

1. Click on **Start** from the main screen.
2. Select **Settings**; click on **Control Panel**.
3. From the Control Panel, double-click on **Add/Remove Hardware**.
4. Click on **Next** and follow the instructions on the screen.

---

## **Installing DOS with Windows Support Software**

This section contains the instructions for installing device drivers and support software for the CD-ROM drive in computers running DOS with Windows under DOS 3.3 or later versions.

1. Insert the Option Diskette into drive A.
2. Open a DOS window.
3. At the DOS prompt, type **A:UINSTALL** and press **Enter**. Follow the instructions on the screen.
4. At the Installation Options menu, select **Install IDE CD-ROM DOS with Windows Support Software** and press **Enter**.
5. Follow the instructions on the screen.

6. UINSTALL will present a menu of installation options. Each of these installation options is equipped with help menus to aid in understanding their function. Install one or more of the following options as appropriate for your computer.

- a. Update for SMARTDRV 4.0

This option must be used if you are using SMARTDRV.EXE version 4.0. Go to the directory which contains SMARTDRV.EXE and type **SMARTDRV ?** to display the version number. See the READ.ME file for more information about SMARTDRV.

- b. DOS 6.2+: Update for SMARTDRV/PhotoCD

This option must be used if you have MS-DOS 6.2 or PC-DOS 6.3 and you want to use Kodak PhotoCD or other multi-session discs on your system. See the READ.ME file for more information about SMARTDRV.

- c. Win 3.0+ - 32 Bit Disk Driver/Primary IDE Port

This option must be used if you installed the IDE CD-ROM on the primary IDE port (or the only IDE port of single-port computer) and you use Windows.

7. Press **F3** to exit from the UINSTALL program.
8. Remove the diskette from drive A and restart the computer.

Use the on-line help screens to select and run the additional installation options appropriate for your computer. If you need additional help to resolve resource conflicts or need other installation

options, refer to "DOS with Windows Software" on page 3-11 and the READ.ME file on the Option Diskette.

---

## Installing OS/2 Support Software

This section contains the instructions for installing device drivers and support software for the CD-ROM drive in computers running OS/2. You must use OS/2 2.1 or later versions. You might also need your OS/2 installation diskettes.

1. From the OS/2 Desktop, select the **OS/2 System** folder.
2. Select **System Setup**; then select **Selective Install**.
3. The System Configuration menu is displayed. Select the **CD-ROM Device Support** option.
4. If you are using OS/2 2.1, select **OK**. For other OS/2 versions, follow the instructions on the screen.
5. You are presented a list of CD-ROM devices. Select **OTHER** from the list; then select **OK**.
6. When the System Configuration menu is displayed again, select **OK**. Follow the instructions on the screen.
7. Select **Install** from the OS/2 Setup and Installation screen.
8. The Source Directory screen is displayed. If OS/2 was not preinstalled on your computer, you might need to insert your installation diskettes into the specified drive. Select **Install**, and follow the instructions on the screen.

9. From the OS/2 Setup and Installation screen, select **OK**. *Do not* shut down and restart your system.
10. Insert the Option Diskette into your diskette drive.
11. From the System Setup folder, select **Device Driver Install**.
12. At the OS/2 Device Driver Installation screen, verify source and destination and select **Install**.
13. At the Select Device Drivers screen, select your drivers from one of the screen options. Choose the appropriate option for your computer and select **OK**.
14. At the OS/2 Device Driver Installation screen, select **Exit** and follow the instructions on the screen.

If you need additional help to resolve resource conflicts or need other installation options, refer to "OS/2 Software" on page 3-15 and the READ.ME file on the Option Diskette.

---

## Using Fast Setup for Dual-Boot OS/2 Warp and Windows

The Fast-Setup program on the Option Diskette is for IBM PC 350, 700, and 750 computers (Models 6576, 6577, 6586, and 6887). If you are installing the drive in one of these computers and you have Dual-Boot OS/2 Warp and DOS with Windows factory-installed, you can use Fast Setup as follows:

1. Insert the Option Diskette into drive A.
2. Open a DOS window.
3. At the DOS prompt, type **A:CDSETUP** and press **Enter**. Follow the instructions on the screen.

The CDSETUP2 program installs both DOS and OS/2 Warp device drivers.

4. Press **F3** to exit from the CDSETUP2 program.
5. Remove the diskette from drive A; shut down and then restart the computer.

## Using the Drive

Follow the instructions for proper care of your CD and proper operation of the CD-ROM drive.

---

### Handling a CD

A CD is a high-density media that must be handled with care and kept clean to insure that it remains readable. These precautions will help to prolong the life of your CD.

**Attention:** Wiping the CD using a circular motion can cause loss of data.

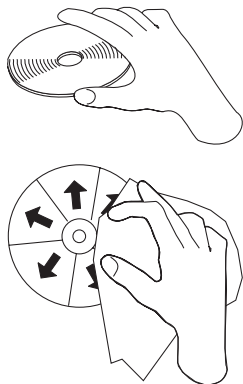

- Handle the CD by the edges or the center hole. Do not touch the surface of the CD.
- To remove dust or fingerprints, wipe the CD from the center to the edge with a soft, lint-free cloth.
- Do not write on the surface.
- Do not place the CD in direct sunlight.
- Do not use commercial cleaners to clean the CD.
- Do not bend the CD.

---

### Loading a CD

To load a CD into a horizontal-bay drive:

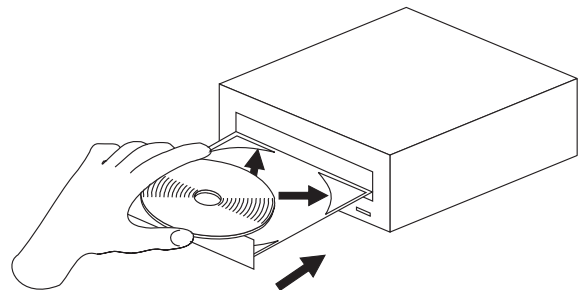

1. Press the Eject/Load button. The tray slides out of the drive.
2. The tray contains four retaining tabs that hold the CD in vertically-mounted drives. They are not needed when you mount the drive horizontally. If the retaining tabs are extended, push them back before trying to place the CD in the tray.
3. Place the CD in the tray with the label facing up.

4. Close the tray by pressing the Eject/Load button, or by gently pushing the tray in.

**Attention:** Do not force the tray to open; do not insert foreign objects into the CD tray.

To load a CD into a vertical-bay drive:

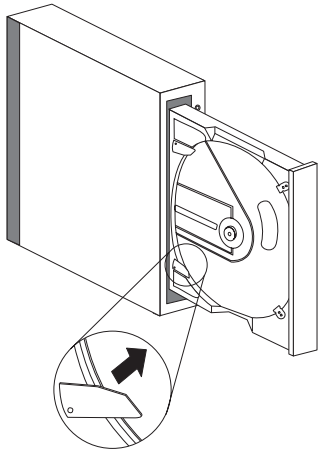

1. Press the Eject/Load button. The tray slides out of the drive.
2. The tray contains four retaining tabs. Use your thumb nail or something similar to rotate all four tabs to the extended position.
3. Insert the CD behind the extended tabs at the back of the tray, label side out. The springs behind the rear tabs compress slightly.

4. Position the CD behind the front tabs and release it. The springs release and hold the CD securely in the tray.

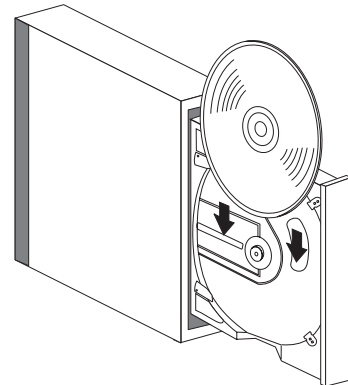

5. Close the tray by pressing the Eject/Load button, or by gently pushing the tray in.

---

## Manually Ejecting a CD

If you press the Eject/Load button and the tray does not slide out, turn off the computer and straighten a large paper clip to form a tool, as shown in the illustration. The straightened end must extend at least 45 mm (1.8 in.). Insert the extended end into the manual eject hole on the front of the drive (see “Front View of the Drive” on page 2-2). Push the paper clip until the tray opens. Gently pull out the tray until you can remove the CD.

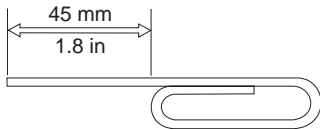

---

## Playing an Audio CD

To play an audio CD, you must have an audio-CD program installed in your computer. You can use the standalone DOS utility, IBMCDPLY, or the OS/2 utility, PLAYCD, to play audio CDs that comes with the option or use utilities provided by your operating system. Windows and OS/2 come with multimedia extensions that include audio-CD player programs.

The following procedures show how to use the audio-CD programs in Windows 3.x, Windows 95, and OS/2. For more information on these programs, see the documentation that comes with your operating system.

### Windows 3.1x

To use the Windows audio utility:

1. Turn on the computer.
2. Load an audio CD into the CD tray.
3. Double-click on **Accessories**.
4. Double-click on **Media Player**, and then on **Device**.
5. Select **CD Audio**.

If you do not see *Media Player* icon or *CD Audio* within the Media Player folder, you must install the Windows CD Audio driver as follows.

1. From the Program Manager select the **Main** folder.

2. Select **Control Panel** then select **Drivers**. You will need to select **MCI CD Audio** if it is not present. Follow the screen instructions if MCI Audio is needed.
  - If you select **New**, you will need your Windows 3.x diskettes.
  - If you select **Current**, continue with the instructions on the screen.

## Windows 95

To use the Windows 95 audio utility:

1. Turn on the computer.
2. Load an audio CD into the CD tray.
3. Click on **Start**.
4. Select **Programs, Accessories, Multimedia**, and then **Media Player**.
5. Click on **Media Player**.
6. Click on **Device**.
7. Select **CD Audio**.

If you do not see *Media Player* or *CD Audio* within the Media Player folder, you must install the Windows CD Audio driver as follows.

1. Open **Computer**, select **Multimedia**, select **Advanced**, select **Media Control Devices**, then select **CD Audio Devices**.
2. Check that the CD device drive is enabled. If the driver is not present or enabled, you will need to install the driver.

## OS/2 Warp

To use the OS/2 audio utility:

1. Turn on the computer.
2. Load an audio CD into the CD tray.
3. Open **Multimedia**.
4. Select and start **Compact Disk**.



---

## Using a Data CD

You can use a data CD to read data files, play games, or run applications. The instructions to use a data CD depends on your operating system.

### DOS

To read a data CD:

1. Turn on the computer.

The operating system displays messages shown below (drive D is the CD-ROM drive in this example):

```
MSCDEX Version 2.2.3  
Copyright (c) Microsoft Corp. 1986-1993
```

```
Drive D:=Driver IBMCD100 unit 0
```

2. Load a data CD into the CD tray.
3. At the DOS prompt, type **dir d:**, and press **Enter**.
4. Verify that you can view the files on the CD.

### Windows 3.1x

To read a data CD:

1. Turn on the computer.
2. Load a data CD into the CD tray.
3. Double-click on **File Manager**.
4. Verify that the *CD* icon is displayed.
5. Double-click on **CD-ROM**.
6. Verify that you can view files on the CD.

### Windows 95

To read a data CD:

1. Turn on the computer.
2. Load a data CD into the CD tray.
3. Click on **My Computer**.
4. Verify that the *CD* icon is displayed.
5. Click on **CD-ROM**.
6. Verify that you can view files on the CD.

### OS/2 Warp

To read a data CD:

1. Turn on the computer.
2. Load a data CD into the CD tray.
3. Double-click on **OS/2 System** and then **Drive**.
4. Verify that the *CD* icon is displayed.
5. Double-click on **CD**.
6. Verify that you can view files on the CD.

## *Solving Problems*

Computer problems can be caused by hardware, software, or user error. Using the information in this section, you might be able to solve such problems yourself or gather helpful information you can pass on to a service technician. You might also need to refer to your computer, operating system, or sound adapter publications to resolve certain issues.

Review the following list for any problem descriptions that might fit your situation.

### **Your computer or CD-ROM drive does not operate correctly or the busy indicator does not light.**

Take the following actions.

1. Check that the CD is loaded with the label side up.
2. Check that all devices are reconnected to the computer and the power outlet.
3. Turn off the computer, unplug the cables from the power outlets for your computer and all attached devices, and remove the computer cover.
4. Check that all power and IDE cables are securely attached. Disconnect the IDE cable and check for bent or misaligned pins. If you do not find any problems, reconnect the cable.
5. Check that the color-coded edge on the IDE cable aligns with pin 1 on the IDE port and is closest to the power

connector on the CD-ROM drive. See “Step 6. Attaching the Cables to the Drive” on page 2-7.

6. Check that the IDE cable is connected to the proper IDE port connection. See “Installation Requirements” on page 2-3 for more information.
7. Check that you set the configuration jumpers to the proper settings. Check the CD-ROM drive and any other device on the IDE cable for the proper settings. See “Step 3. Determine the IDE Port and Device Jumper Settings” on page 2-6 for more information.
8. If the middle connector on the IDE cable is attached to the IDE port on the system board, remove the connector and reattach the cable. If there is only one device on the IDE port, attach the connector at one end of the cable to the IDE port and the connector at the other end to the device leaving the middle connector (if there is one) open.

If there are two devices on the IDE port, attach the connector at one end of the cable to the IDE port. If there is a disk drive, attach it to the connector at the other end of the cable and attach the CD-ROM drive to the middle connector.

### **You cannot access the CD-ROM (DOS and Windows 3.1) or the CD-ROM icon (Windows) does not display.**

Your CD-ROM device driver might not be loaded or cannot be not found. Before checking the CONFIG.SYS and

AUTOEXEC.BAT files, make a backup copy of these files in a convenient directory. At the DOS prompt:

Type **copy CONFIG.SYS CONFIG.IBM**, and press **Enter**.

Type **copy AUTOEXEC.BAT AUTOEXEC.IBM**, and press **Enter**.

Use a text editor such as E or Edit from the DOS prompt. (The following instructions use the E text editor.) Type **E CONFIG.SYS**, press **Enter**.

1. Insert the following line at the top of the CONFIG.SYS file to allow for more than five drive letters, if needed.

```
lastdrive=z
```

2. Check for the line that refers to the device driver.

```
DEVICEHIGH=C:\IBMIDECD.SYS /D:IBMCD100
```

If this line is not present, add it.

3. Save any changes and exit the CONFIG.SYS file.

Type **E AUTOEXEC.BAT**, press **Enter**. (The following instructions use the E text editor.)

1. Check for the line that refers to the device driver.

```
LH C:\MSCDEX /D:IBMCD100 /M:10
```

If this line is not present, add it.

2. If the Windows screen automatically displays after you start your computer, check that the line

```
LH C:\MSCDEX /D:IBMCD100 /M:10
```

comes before the line that starts Windows (*WIN*). If not, move the MSCDEX statement above this line in the file.

3. Save any changes and exit the AUTOEXEC.BAT file.

Check that the device drivers are on the hard disk drive and in the correct directory.

```
C:\IBMIDECD.SYS  
C:\MSCDEX
```

If the drivers are not present, reinstall them. See the READ.ME file on the Option Diskette for more information.

**You cannot access the CD-ROM or the CD-ROM icon does not display (OS/2).**

Your CD-ROM device driver might not be loaded or cannot be found. Before checking the CONFIG.SYS file, make a backup copy of this file in a convenient directory. At the OS/2 prompt type **copy CONFIG.SYS CONFIG.IBM** and press **Enter**.

Use a text editor such as EPM or E from the OS/2 prompt. The following instructions use the EPM editor.

1. Type **EPM CONFIG.SYS**. Check for the lines that refer to the device driver.

```
DEVICE=C:\OS2\BOOT\OS2CDROM.DMD /Q
IFS=C:\OS2\BOOT\CDFS.IFS /Q
DEVICE=C:\OS2\MDOS\VCDROM.SYS
BASEDEV=IBMIDEC.D.FLT
```

If these lines are not present, add them.

2. Save any changes and exit the CONFIG.SYS file.

Check that the device drivers are on the hard disk drive and in the correct directory.

```
C:\OS2\BOOT\OS2CDROM.DMD
C:\OS2\BOOT\CDFS.IFS
```

If the drivers are not present, reinstall them. See the READ.ME file on the Option Diskette for more information.

### **The CD-ROM is not recognized by the operating system or the drive is erratic.**

Some computers, such as ValuePoint models 6472, 6482, 6484, 6492, and 6494, have a *compatible* and *high performance* mode for mass storage devices. The CD-ROM drive functions better when this mode is set to compatible with these computers. (Be aware that you should use the *high performance* mode unless your computer has a problem and you must use the *compatible* mode.)

Check the configuration-setup information for your computer.

1. Scroll down to the **Mass Storage Devices** section.
2. **Mass Storage Devices** contains the entries **Primary IDE Mode** and **Secondary IDE Mode**. These entries are used to set the performance mode of each IDE port. Set the

mode to **Compatible** for the port on which you installed your CD-ROM drive.

Other IBM and non-IBM computers might have similar symptoms. Check to see if your BIOS or configuration-setup utility provides for the *compatible* and *high performance* mode for IDE performance. For these computers, use the *compatible* mode for slower IDE devices such as this CD-ROM drive. Refer to your the documentation that comes with your computer for additional details on selecting IDE performance modes. Many older computers will not have a selection of IDE performance modes.

### **The computer does not recognize the CD-ROM drive with the device drivers loaded.**

Check for incompatibilities between the CD-ROM device driver and other drivers or other hardware in your computer by creating a System Diskette with minimum CONFIG.SYS and AUTOEXEC.BAT system files.

1. Before creating special CONFIG.SYS and AUTOEXEC.BAT files, make a backup copy of these files in a convenient directory. From the DOS prompt (if you have not already done so),

Type **copy CONFIG.SYS CONFIG.IBM** and press **Enter**.

Type **copy AUTOEXEC.BAT AUTOEXEC.IBM** and press **Enter**.

2. Create a System Diskette and copy the device drivers onto it. For DOS and Microsoft Windows 3.x:
  - a. Insert a blank diskette into drive A.
  - b. At the DOS prompt, type **format a: /s** and press **Enter**. The /s parameter creates the System Diskette. Follow the instructions on the screen.
  - c. When the format process completes, copy the C:\IBMIDECD.SYS and C:\MSCDEX files to the System Diskette.
  - d. Using a text editor, create a minimum CONFIG.SYS system file on the System Diskette to support only a CD-ROM drive. The following procedure uses the E text editor to create the CONFIG.SYS file from the A prompt.
    - 1) Type **e config.sys** and press **Enter**.
    - 2) In the editor, type **lastdrive=z** and press **Enter**.
    - 3) Type **device=a:\ibmidecd.sys /d:ibmcd100** and press **Enter**.
    - 4) Save the CONFIG.SYS file and exit the editor.
  - e. Using a text editor, create a minimum AUTOEXEC.BAT system file on the System Diskette to support only a CD-ROM drive. The following procedure uses the E text editor to create the AUTOEXEC.BAT file from the A prompt.
    - 1) Type **e autoexec.bat** and press **Enter**.
    - 2) Type **a:\mscdex /d:ibmcd100 /m:10** and press **Enter**.
    - 3) Save the AUTOEXEC.BAT file and exit the editor.
3. Turn off the computer and check that the System Diskette is in the diskette drive.
4. Restart the computer (the computer should startup from the System Diskette).
5. Observe the startup messages and check that the device driver, IBMIDECD.SYS loads. When MSCDEX loads, observe the drive letter that the computer assigns to the CD-ROM drive.
6. Load a data CD into the CD tray then wait until the busy indicator is not lit.
7. Attempt to read the CD by typing **dir x:** where x is the CD-ROM drive assigned after the MSCDEX message.
  - If the computer is able to read the CD, a conflict appears to be present related to your device drivers loaded in either the CONFIG.SYS or AUTOEXEC.BAT FILES. You need to resolve this device driver conflict. You might have to set some configuration parameters for your installation, refer to Appendix B, "Device Driver Configuration Settings" on page 3-11 for more information.
  - If you are unable to access the CD, you might have a hardware problem. If you are unable to read the

CD or a drive letter is not assigned by MSCDEX, go to the next step.

8. Turn off the computer, unplug the cables from the power outlets for your computer and all attached devices, and remove the computer cover.
9. Disconnect the IDE and power cable for all IDE devices except the CD-ROM drive.
10. Configure the CD-ROM drive as a master and connect it to last IDE connector on the primary IDE port.
11. Reinstall the computer cover. Reconnect the keyboard; plug the power cords into electrical outlets. (The System Diskette should be in the diskette drive and a data CD loaded in the CD-ROM.)
12. Restart the computer.
13. Attempt to read the CD by typing **dir C:**. (The CD-ROM drive is drive C because it is the only device connected to the IDE port.)
  - If the computer is able to read the CD, a conflict appears to be present related to one of the devices that was installed on your computer. You need to resolve this device driver conflict. Check the configuration jumper settings for the other devices or refer to your device documentation. To contact your hard disk drive manufacturer, see Appendix C, "Hard Disk Drive Manufacturers" on page 3-17 for more information.

- If you are unable to access the CD, you might have a hardware problem. If the CD-ROM drive still does not read the data CD directory, the CD-ROM drive might be defective. Go to Appendix D, "Technical Support" on page 3-17.

**You install the CD-ROM drive to a computer attached to a network.**

The network connection might require additional consideration such as a specific drive letter designated for the CD-ROM. For additional information, refer to "Networking" on page 3-15.

**The CD cannot be read.**

Consider the following actions.

- The CD might be dirty; clean it as described in "Handling a CD" on page 2-12.
- The CD might be defective; try another CD.
- The CD is not ISO-9660 or High Sierra Group (HSG) compatible. Check with your place of purchase.

**There is no sound from the CD.**

Consider the following actions.

- Check that you are using an audio CD and not a data CD.
- Adjust the volume control on the drive. See "Front View of the Drive" on page 2-2 if headphones are connected to the front of the drive.

- Adjust the sound-adapter volume control. See the documentation that comes with your sound adapter and audio-CD player program.
- Turn off the computer, unplug the cables from the power outlets for your computer and all attached devices, and remove the computer cover. Check that the audio-signal cable connects the CD-ROM drive with the sound adapter.

**You get a CD error message.**

These are actions for some common error messages.

- **CDR-103**  
The CD in the CD-ROM drive is not a High Sierra or ISO 9660 format. The CD-ROM drive does not support this format.
- **CDR-101**  
The "not ready reading the drive" situation occurs if you try to access the CD-ROM drive before the drive is ready. The busy indicator lights when you attempt to access the drive after loading a CD into the CD tray. Wait until the busy indicator is no longer lit before attempting to access the drive.

**The connectors on the audio cables provided do not allow connection to your sound adapter.**

Some sound adapters might require a special cable. See the documentation that comes with your sound adapter.

You might have to separately purchase an audio cable for the CD-ROM drive. The audio-out connector on the CD-ROM drive requires a MPC-2 compliant Molex 70066-G connector. (Refer to "Back View of the Drive" on page 2-2 to locate the audio connector.) If you are using an IBM computer or IBM sound adapter, refer to Appendix D, "Technical Support" on page 3-17 for assistance.

---

## Diagnostics

To help you solve CD-ROM drive problems, the Option Diskette contains a general purpose diagnostic program. You must successfully load the CD-ROM drive device drivers before starting the diagnostics. The program can be run only from the DOS prompt. You cannot run the diagnostic program in a DOS session under OS/2 or in DOS under Windows.

To start the diagnostic program, go to the DOS prompt and change to drive A. Then insert the Option Diskette, type **CDDIAG** and press **Enter**.

---

## Additional Help

The READ.ME file on the Option Diskette includes troubleshooting hints. If you follow these instructions and you still have a problem, go to Appendix D, "Technical Support" on page 3-17.

## Appendix B. Device Driver Configuration Settings

This section contains installation option information for DOS with Windows and OS/2. Use the on-line help during the installation and refer to the READ.ME file on the Option Diskette for additional information.

---

### DOS with Windows Software

User requirements vary, and you might need to customize the setup which UINSTALL has installed on your computer. This section provides information and describes parameters that you might need to change or add for your installation.

#### Device Driver (IBMIDECD.SYS)

Most computers will function adequately with the default settings for this file. However, there are some parameters that can be changed if necessary. This section explains the function of each parameter. Use a text editor to modify the appropriate line in your CONFIG.SYS file. For the IBMIDECD.SYS device driver, the line in CONFIG.SYS is in the following format:

```
DEVICE=[drive:][path ]IBMIDECD.SYS /D:device name  
      [/P:xxx,yy] [/A:n] [/U:n] [/L:xx] [/T:n] [/I:n]
```

(Do not truncate the actual device driver entry. Place the complete DEVICE=.. on one line in the CONFIG.SYS file.)

```
[drive:][path]IBMIDECD.SYS
```

Specifies the location (drive and directory) and name of the device driver file.

Use the following options to configure the device driver.

#### **/D:device name**

Specifies the device name of the CD-ROM drive. This must be identical to the device name specified in the MSCDEX.EXE parameters, for example:

```
DEVICE=C:\IBMIDECD.SYS /D:IBMCD100
```

#### **/P:xxx,yy**

Specifies the address and interrupt level of the port to which the IDE CD-ROM drive is connected.

The device driver automatically checks the industry standard primary IDE port (address 1F0, interrupt 14) and secondary IDE port (address 170, interrupt 15). The */P* parameter is not needed if your CD-ROM drive is on either of these ports. However, if your computer (or IDE adapter) uses different IDE port addresses or interrupts, you must use this option. Refer to the instructions that came with your computer or IDE adapter to understand how your computer or adapter is configured.

xxx is the base address of the IDE port.

1F0 for the primary IDE port (Port 1)

170 for the secondary IDE port (Port 2)

yy is the interrupt (IRQ) level.

14 for the primary IDE port (Port 1)



15 or 10 for the secondary IDE port (Port 2)

As an example, when four drives have been connected, the syntax in the CONFIG.SYS file would be:

```
DEVICE=C:IBMIDEC.D.SYS /D:IBMCD100 /P:1F0,14  
/P:170,15 /P:1E0,12 /P:160,10
```

(Do not truncate the actual device driver entry. Place the complete DEVICE=.. on one line in the CONFIG.SYS file.)

#### **/A:n**

Specifies the audio play mode. For a stereo CD, /A:0 or /A:1 is acceptable. For a monaural CD (left or right channel only), /A:1 will play the monaural audio signal from both the right and left channels. The default is n=0.

#### **/U:n**

Initialize with the tray locked or unlocked. /U:0 is *unlock*. /U:1 is *lock*. The default is n=0. This command might be used if you wish to secure your CD in the drive.

#### **/L:xx**

Specifies the message language where *xx* designated the supported languages.

<b>US</b>	English (default, does not need to be specified)
<b>GR</b>	German
<b>FR</b>	French
<b>SP</b>	Spanish
<b>IT</b>	Italian
<b>JP</b>	Japanese

#### **/T:n**

Initializes with time delays built into the IDE read loop. Only use this parameter in computers that do not support the IOCHRDY signal on the IDE bus, and that read from the IDE port faster than the CD-ROM can provide data. This is a very uncommon situation and normally is not required in most computers.

*n* is a relative timing parameter that depends on processor speed. The larger the value of *n*, the slower the driver will transfer data. Valid values for *n* are 0 through 99. The default for *n* is 0, and the /T parameter is not required.

#### **/I:n**

Enables interrupt sharing. If n=1, interrupt sharing is enabled. If n=0, interrupt sharing is disabled. The default value is 0. Enable this parameter when the IDE interrupt must be shared with another device. For example, a PS/2 9577 computer with IDE could share interrupt 14 with the IBM SCSI Adapter /A.

### **Microsoft CD-ROM Extensions**

Microsoft CD-ROM Extensions (MSCDEX.EXE) is an executable program that works in conjunction with the device driver (IBMIDEC.D.SYS) to allow your computer to access CDs as if they were DOS-formatted disks. MSCDEX is specifically designed to work with DOS and Windows.

UNINSTALL automatically adds an MSCDEX statement to your AUTOEXEC.BAT file. You can modify the default MSCDEX parameters to customize your installation. This section explains the

function of each parameter. A text editor can be used to modify the MSCDEX statement in your AUTOEXEC.BAT file.

The following is syntax of the MSCDEX.EXE entry in AUTOEXEC.BAT where specifies the location (drive and directory) of the MSCDEX.EXE file. *[drive:][path]MSCDEX.EXE*.

```
[drive:] [path]MSCDEX.EXE /D:device name [/M:n] [/E] [/V]
[/L:drive letter] [/K] [/S]
```

(Do not truncate the actual device driver entry. Place the complete line in the AUTOEXEC.BAT file.)

Use the following options to configure the device driver.

#### **/D:device name**

Specifies the name of the CD-ROM drive (eight characters maximum). This must be identical to the device name specified in the device driver in the CONFIG.SYS file. For example:

```
C:\MSCDEX.EXE /D:IBMCD100
```

You might support multiple CD-ROM drives (of different types) by installing each of their drivers (naming them different names) and placing a /D:device name in the MSCDEX line for each different drive. For example, if you wanted to support an IBM IDE CD-ROM drive and an IBM SCSI CD-ROM drive, your CONFIG.SYS file could have these statements:

```
DEVICE=C:\IBMIDECD.SYS /D:IDE_CD
DEVICE=C:\IBMCDROM.SYS /D:SCSI_CD
```

and your AUTOEXEC.BAT file would have this statement:

```
C:\MSCDEX /D:IDE_CD /D:SCSI_CD
```

#### **/M:nn**

Specifies the number of sector buffers for temporary storage of the most recent CD data. For example, to specify twelve sector buffers you would use:

```
C:\MSCDEX.EXE /D:IBMCD100 /M:12
```

UINSTALL will set this value to 10. The default value for MSCDEX with no /M parameter is 4.

The greater this value, the better the CD-ROM drive will perform. However, each buffer uses about 2KB of memory, and specifying too many buffers might slow down your computer or interfere with other programs which have large memory usage requirements. Using expanded memory (see the /E option in this section) or loading MSCDEX.EXE into high memory (refer to your MS-DOS User Manual or Memory Manager User Manual) might allow you to specify a larger number of buffers to enhance CD-ROM performance without adversely affecting programs that have large memory usage requirements.

#### **/E**

Instructs the computer to use expanded memory, if available. For example:

```
C:\MSCDEX.EXE /D:IBMCD100 /E
```

Note that you must first load an expanded memory driver before using this option. If no expanded memory driver is loaded, the following error message appears, *Expanded Memory not present or not usable*.

#### **/V**

Instructs the computer to display a summary of RAM allocation and expanded memory usage at startup time.

#### **/L:drive letter**

Specifies the drive letter to be assigned to the first CD-ROM drive. Do not assign a letter already used by an existing drive or your computer will be unable to access the CD-ROM drive. For example, you might use:

```
C:\MSCDEX.EXE /D:IBMCD100 /L:F
```

Normally, the CD-ROM drive is assigned to the next available drive letter after the devices such as diskette drives and hard disk drives. Therefore, you only need to use this option if you wish to assign a drive letter beyond the last letter previously allocated by DOS.

#### **/K**

Tells MSCDEX.EXE to use Kanji (Japanese) file structures, if present, rather than the default alphanumeric file structures.

#### **/S**

Instructs MSCDEX.EXE to allow sharing of CD-ROM drives on networked computers.

## **Conserving DOS Conventional Memory**

If the CD-ROM support software is loaded in DOS conventional memory (below 640 KB RAM), there might be insufficient memory to run some DOS applications. The UINSTALL program attempts to load the IDE CD-ROM device driver and MSCDEX into upper memory, when possible, to avoid this problem.

See the following topics in your DOS User's Guide for more information on techniques to conserve conventional memory:

- **DOS=UMB, DOS=HIGH,UMB (CONFIG.SYS entry)**  
This loads DOS high and enables the use of upper memory. This is essential to effectively load MSCDEX and the IDE CD-ROM device driver in upper memory.
- **HIMEM.SYS (CONFIG.SYS entry) p.** This is a device driver that manages Extended memory (RAM memory above 1 MB ). Windows automatically loads this driver.
- **EMM386.EXE (CONFIG.SYS entry) p.** This is a device driver that allows the Extended memory made available by HIMEM.SYS to be used as expanded memory. The MSCDEX /E parameter might be used in conjunction with this driver to move the cache allocated by MSCDEX into this memory, thus freeing some conventional memory.
- **MEM /C /P (use from DOS prompt)**  
This is a useful DOS utility that will display the current memory allocation in your computer to help you understand where device

drivers and programs are located. To display the MEM parameters available, at the DOS prompt type **mem /?**.

## Enhancing Performance

Following are two ways to enhance CD-ROM performance on your computer:

1. Allocate more MSCDEX cache (see /M parameter for MSCDEX).
2. Allow SMARTDRV to cache CD-ROM accesses.

The installation option "DOS 6.2+ - Update for SMARTDRV/PhotoCD" disables the cache CD-ROM data function. Multi-session CDs are not compatible with the SMARTDRV caching method. If you do not plan to use PhotoCD or multiple-session CDs, you might re-enable caching by removing the /U parameter from the SMARTDRV line in your AUTOEXEC.BAT or CONFIG.SYS file. This might improve the performance of some CD-ROM applications. You must have SMARTDRV 5.0 or higher to cache CD-ROM data.

## Networking

If you are using the IDE CD-ROM drive in a DOS Network server you must make the following changes:

1. Add the /S parameter to the MSCDEX line in the AUTOEXEC.BAT file.
2. Check that the MSCDEX line is located after the line that loads the network services (NET START for IBM PC LAN program).
3. Do one of the following, depending on your operating system:

- A computer using DOS 3.3 must have the PC Local Area Network (LAN) Program Corrective Service Diskette level IP00755 or later installed.
- A computer using DOS 4.0 must have the DOS Corrective Service Diskette level UR 29015 or higher installed. (The computer cannot be configured as an Extended Services Domain Controller for the IBM PC LAN Program.)
- Contact your IBM Authorized Dealer for more information about the PC LAN Program Corrective Service Diskette or the DOS Corrective Service Diskette.

---

## OS/2 Software

User requirements vary, and you might need to customize the setup which DDINSTALL has installed on your computer. This section provides information and describes parameters that you might need to change or add for your installation.

### Device Manager Driver

OS/2 uses the OS2CDROM.DMD device driver

```
DEVICE=OS2CDROM.DMD [Options]
```

to control all CD-ROM devices. The following options are available:

- /V Instructs the computer to display the installation details (verbose mode).
- /Q Suppresses messages during initialization (quiet mode).

## Device Driver Filter

OS/2 uses the device driver filter IBMIDECD.FLT for ATAPI (IDE) CD-ROM drives.

BASEDEV=IBMIDECD.FLT [Options]

The following option is available:

**/V** Instructs the computer to display installation details.

## Installable File System Driver

The file system driver for OS/2 is CDFS.IFS. The following options are available:

**/C:n** Indicates how many 64K RAM segments will be used for the sector cache. The default is two 64K RAM segments.

**/M:n** Indicates the maximum number of file sectors to be read at a time. The default is eight sectors.

**/K** Use Kanji supplementary volume descriptor.

**/Q** Suppresses messages during initialization.

## IDE Adapter Device Driver

The following IDE device drivers are available:

BASEDEV=IBM1S506.ADD (for ISA computers)  
BASEDEV=IBM2IDE.ADD (for Micro Channel computers)

This device driver controls IDE hard disk drives and IDE CD-ROM drives. From the OS/2 command prompt, type **help IBM1S506** to see the optional parameters which are available. Use this command for Micro Channel computers also.

Special parameters are required if your computer has an IDE controller that does not use a standard interrupt. Check the **/A** and **/IRQ** parameters in the OS/2 help utility.

## Appendix C. Hard Disk Drive Manufacturers

Use the following table for disk manufacturer information, as needed. For manufacturers not in the table, contact your IBM reseller.

Disk Manufacturer	Telephone	BBS/Fax
Maxtor Corporation (USA)	(800) 2MAXTOR (303) 678-2045	<u>BBS</u> (303) 678-2222 (2400 baud) (303) 678-2020 (9600 baud) <u>Fax</u> (303) 678-2260
Quantum Peripherals (USA)	(800) 826-8022	<u>BBS</u> (800) 472-9799 <u>Fax Back</u> (800) 4DISKFAX
Seagate Technology, Inc.	(800) SEAGATE	<u>BBS</u> (408) 438-8771 <u>Fax Back</u> (800) SEAGATE (408) 456-4496
Western Digital Corporation (USA)	(714) 932-4900 <u>Technical Support</u> (800) 832-4778	<u>BBS</u> (714) 753-1234

## Appendix D. Technical Support

Before calling, you might be able to solve the problem yourself. Follow the instructions in "Solving Problems" on page 2-17. If the problem still is unresolved, be prepared to discuss the problem solving actions taken and the results seen with a technical support representative.

---

### Step 1. Preparing for the Call

To assist the technical support representative, have available as much of the following information as possible:

1. Computer manufacturer and computer model
2. Option name: IBM 16X MAX IDE CD-ROM Drive
3. Option number: 76H6110
4. Proof of purchase
5. Exact wording of any error message
6. Description of the problem
7. Operating system and version
8. Installed devices and adapters
9. Listing of your system files, CONFIG.SYS and AUTOEXEC.BAT. (Access to a fax to send a copy of your system files could expedite your telephone call.)

If possible, be at your computer. Your technical support representative might want to walk you through the problem during the call.

---

## Step 2. Placing the Call to IBM

Technical support is available during the warranty period to answer any questions about your new IBM option. Support response time will vary depending on the number and nature of calls received.

For the support telephone number and support hours by country, refer to the following table or to the enclosed technical support insert. If the number is not provided in the table or on an insert, contact your IBM reseller or IBM marketing representative.

<i>Support 24 hours a day, 7 days a week</i>	
Canada	1-800-565-3344
Puerto Rico	1-800-772-2227
United States	1-800-772-2227

## Appendix E. Warranty and Notices

---

### Product Warranty

The following warranty information applies to products purchased in the United States, Canada, and Puerto Rico. For warranty terms and conditions for products purchased in other countries, see the enclosed Warranty insert, or contact your IBM reseller or IBM marketing representative.

International Business Machines Corporation

Armonk, New York, 10504

### Statement of Limited Warranty

*The warranties provided by IBM in this Statement of Limited Warranty apply only to Machines you originally purchase for your use, and not for resale, from IBM or your reseller. The term "Machine" means an IBM machine, its features, conversions, upgrades, elements, or accessories, or any combination of them. Unless IBM specifies otherwise, the following warranties apply only in the country where you acquire the Machine. If you have any questions, contact IBM or your reseller.*

**Machine:** IBM 16X MAX IDE CD-ROM Drive

**Warranty Period\*:** One Year

*\*Contact your place of purchase for warranty service information.*

### Production Status

Each Machine is manufactured from new parts, or new and used parts. In some cases, the Machine may not be new and may have been previously

installed. Regardless of the Machine's production status, IBM's warranty terms apply.

### **The IBM Warranty for Machines**

IBM warrants that each Machine 1) is free from defects in materials and workmanship and 2) conforms to IBM's Official Published Specifications. The warranty period for a Machine is a specified, fixed period commencing on its Date of Installation. The date on your receipt is the Date of Installation, unless IBM or your reseller informs you otherwise.

During the warranty period IBM or your reseller, if authorized by IBM, will provide warranty service under the type of service designated for the Machine and will manage and install engineering changes that apply to the Machine.

For IBM or your reseller to provide warranty service for a feature, conversion, or upgrade, IBM or your reseller may require that the Machine on which it is installed be 1) for certain Machines, the designated, serial-numbered Machine and 2) at an engineering-change level compatible with the feature, conversion, or upgrade. Many of these transactions involve the removal of parts and their return to IBM. You represent that all removed parts are genuine and unaltered. A part that replaces a removed part will assume the warranty service status of the replaced part.

If a Machine does not function as warranted during the warranty period, IBM or your reseller will repair it or replace it with one that is at least functionally equivalent, without charge. The replacement may not be new, but will be in good working order. If IBM or your reseller is unable to repair or replace the Machine, you may return it to your place of purchase and your money will be refunded.

If you transfer a Machine to another user, warranty service is available to that user for the remainder of the warranty period. You should give your proof of purchase and this Statement to that user. However, for Machines which have a life-time warranty, this warranty is not transferable.

### **Warranty Service**

To obtain warranty service for the Machine, you should contact your reseller or call IBM. In the United States, call IBM at **1-800-772-2227**. In Canada, call IBM at **1-800-565-3344**. You may be required to present proof of purchase.

IBM or your reseller will provide certain types of repair and exchange service, either at your location or at IBM's or your reseller's service center, to restore a Machine to good working order.

When a type of service involves the exchange of a Machine or part, the item IBM or your reseller replaces becomes its property and the replacement becomes yours. You represent that all removed items are genuine and unaltered. The replacement may not be new, but will be in good working order and at least functionally equivalent to the item replaced. The replacement assumes the warranty service status of the replaced item. Before IBM or your reseller exchanges a Machine or part, you agree to remove all features, parts, options, alterations, and attachments not under warranty service. You also agree to ensure that the Machine is free of any legal obligations or restrictions that prevent its exchange.

You agree to:

1. obtain authorization from the owner to have IBM or your reseller service a Machine that you do not own; and
2. where applicable, before service is provided —
  - a. follow the problem determination, problem analysis, and service request procedures that IBM or your reseller provide,
  - b. secure all programs, data, and funds contained in a Machine, and
  - c. inform IBM or your reseller of changes in a Machine's location.

IBM is responsible for loss of, or damage to, your Machine while it is 1) in IBM's possession or 2) in transit in those cases where IBM is responsible for the transportation charges.

### **Extent of Warranty**



IBM does not warrant uninterrupted or error-free operation of a Machine.

The warranties may be voided by misuse, accident, modification, unsuitable physical or operating environment, improper maintenance by you, removal or alteration of Machine or parts identification labels, or failure caused by a product for which IBM is not responsible.

THESE WARRANTIES REPLACE ALL OTHER WARRANTIES OR CONDITIONS, EXPRESS OR IMPLIED, INCLUDING, BUT NOT LIMITED TO, THE IMPLIED WARRANTIES OR CONDITIONS OF MERCHANTABILITY AND FITNESS FOR A PARTICULAR PURPOSE. THESE WARRANTIES GIVE YOU SPECIFIC LEGAL RIGHTS AND YOU MAY ALSO HAVE OTHER RIGHTS WHICH VARY FROM JURISDICTION TO JURISDICTION. SOME JURISDICTIONS DO NOT ALLOW THE EXCLUSION OR LIMITATION OF EXPRESS OR IMPLIED WARRANTIES, SO THE ABOVE EXCLUSION OR LIMITATION MAY NOT APPLY TO YOU. IN THAT EVENT SUCH WARRANTIES ARE LIMITED IN DURATION TO THE WARRANTY PERIOD. NO WARRANTIES APPLY AFTER THAT PERIOD.

#### **Limitation of Liability**

Circumstances may arise where, because of a default on IBM's part or other liability you are entitled to recover damages from IBM. In each such instance, regardless of the basis on which you are entitled to claim damages from IBM (including fundamental breach, negligence, misrepresentation, or other contract or tort claim), IBM is liable only for:

1. damages for bodily injury (including death) and damage to real property and tangible personal property; and
2. the amount of any other actual direct damages or loss, up to the greater of U.S. \$100,000 or the charges (if recurring, 12 months' charges apply) for the Machine that is the subject of the claim.

UNDER NO CIRCUMSTANCES IS IBM LIABLE FOR ANY OF THE FOLLOWING: 1) THIRD-PARTY CLAIMS AGAINST YOU FOR LOSSES OR DAMAGES (OTHER THAN THOSE UNDER THE FIRST ITEM LISTED ABOVE); 2) LOSS OF, OR DAMAGE TO, YOUR RECORDS OR DATA; OR 3) SPECIAL, INCIDENTAL, OR INDIRECT DAMAGES OR FOR ANY ECONOMIC CONSEQUENTIAL DAMAGES (INCLUDING LOST PROFITS OR SAVINGS), EVEN IF IBM OR YOUR RESELLER IS INFORMED OF THEIR POSSIBILITY. SOME JURISDICTIONS DO NOT ALLOW THE EXCLUSION OR LIMITATION OF INCIDENTAL OR CONSEQUENTIAL DAMAGES, SO THE ABOVE EXCLUSION OR LIMITATION MAY NOT APPLY TO YOU.

---

## System Programs License Agreement

**PLEASE READ THIS AGREEMENT CAREFULLY BEFORE USING THESE PROGRAMS. INITIAL USE OF THE SYSTEM OR THESE PROGRAMS INDICATES YOUR ACCEPTANCE OF THESE TERMS.**

### License

This is a license agreement ("Agreement") for IBM system programs ("Programs") which are provided on the enclosed IBM diskette(s), or may be recorded on other media included in this package, or on an IBM system ("System"). A System includes IBM machines, features, conversions, upgrades, and options, either separately or in any combination.

IBM may also include other programs in this package which may be licensed under different terms and conditions. Please refer to the license agreement(s) accompanying such other programs for the terms and conditions governing their use.

International Business Machines Corporation ("IBM") owns or has rights to the Programs which are protected by copyright and licensed, not sold. If you are a rightful possessor of a System, or if you have obtained Programs for the purpose of maintaining a System, IBM, or the applicable IBM country organization, grants you a license to use the Programs as part of or in conjunction with a System, or to restore and maintain the Programs. You obtain no rights other than those granted to you under this license. IBM retains title to the Programs and all copies you make of them.

**YOU MUST REPRODUCE THE IBM COPYRIGHT NOTICE AND ANY LEGENDS ON EACH COPY OF A PROGRAM YOU CREATE.**

This license authorizes you to:

1. use the Programs as part of, or in conjunction with, a System as specified in the IBM documentation;

2. modify or adapt only the SETUP and ADAPTER DESCRIPTION FILES (@XXXX.ADF), if applicable, to enable a System to operate in accordance with IBM's Official Published Specifications;
3. copy the Programs for backup, or archival purposes;
4. make copies of the Programs and distribute them to a rightful possessor of a System and to install the Programs for a rightful possessor (but only to the extent necessary to restore or maintain the System), provided that you supply such party a copy of this Agreement. Initial use of the Programs by such party shall indicate acceptance of this Agreement; and
5. transfer possession of these Programs and diskette(s) to another party in conjunction with the transfer of a System, provided that you supply a copy of this Agreement to such party. Initial use of these Programs by such party shall indicate acceptance of this Agreement. Such transfer of possession of the Programs shall terminate your license from IBM, and you must, at the same time, either transfer to such party or destroy all your other copies of the Programs.

You may NOT:

1. use, merge, copy, display, adapt, modify, execute, distribute or transfer the Programs, except as authorized by this license;
2. reverse assemble, reverse compile, decode, or translate the Programs; or
3. sublicense, rent, lease, or assign Programs.

### Warranty

IBM warrants the Programs in accordance with the Statement of Limited Warranty that accompanied your System, which is hereby incorporated by reference.

## General

You may terminate your license at any time. IBM may terminate your license if you fail to comply with the terms and conditions of this Agreement. In either event, you must destroy all your copies of the Programs.

You are responsible for the payment of any taxes, including personal property taxes, resulting from this Agreement.

Neither party may bring an action, regardless of form, more than two years after the cause of action arose.

If you acquire the Programs in the United States, this license is governed by the laws of the State of New York. If you acquired the Programs in Canada, this license is governed by the laws of the Province of Ontario. Otherwise, this license is governed by the laws of the country in which you acquired the Programs.

---

## Notices

References in this publication to IBM products, programs, or services do not imply that IBM intends to make these available in all countries in which IBM operates. Any reference to an IBM product, program, or service is not intended to state or imply that only that IBM product, program, or service may be used. Subject to IBM's valid intellectual property or other legally protectable rights, any functionally equivalent product, program, or service may be used instead of the IBM product, program, or service. The evaluation and verification of operation in conjunction with other products, except those expressly designated by IBM, are the responsibility of the user.

IBM may have patents or pending patent applications covering subject matter in this document. The furnishing of this document does not give you any license to these patents. You can send license inquiries, in writing, to:

IBM Director of Licensing  
IBM Corporation  
500 Columbus Avenue  
Thornwood, NY 10594  
U.S.A.

---

## Trademarks

The following terms are trademarks of the IBM Corporation in the United States or other countries or both:

IBM	OS/2
PS/2	ValuePoint
Micro Channel	

The following terms are trademarks of other companies:

Kodak	Eastman Kodak Company
Quantum	Quantum Corporation
Seagate	Seagate Technology, Inc.
Western Digital	Western Digital Corporation

Microsoft and Windows are trademarks or registered trademarks of Microsoft Corporation.

Other company, product, and service names may be trademarks or service marks of others.

---

## Electronic Emission Notices

### Federal Communications Commission (FCC) Statement

**Note:** This equipment has been tested and found to comply with the limits for a Class B digital device, pursuant to Part 15 of the FCC Rules. These limits are designed to provide reasonable protection against harmful interference in a residential installation. This equipment generates, uses, and can radiate radio frequency energy and, if not installed and used in accordance with the instructions, may cause harmful interference to radio communications. However, there is no guarantee that interference will not occur in a particular installation. If this equipment does cause harmful interference to radio or television reception, which can be determined by turning the equipment off and on, the user is encouraged to try to correct the interference by one or more of the following measures:

- Reorient or relocate the receiving antenna.
- Increase the separation between the equipment and receiver.
- Connect the equipment into an outlet on a circuit different from that to which the receiver is connected.
- Consult an IBM authorized dealer or service representative for help.

IBM is not responsible for any radio or television interference caused by unauthorized changes or modifications to this equipment. Unauthorized changes or modifications could void the user's authority to operate the equipment.

This device complies with Part 15 of the FCC Rules. Operation is subject to the following two conditions: (1) this device may not cause harmful interference, and (2) this device must accept any interference received, including interference that may cause undesired operation.

### **Industry Canada Class B Emission Compliance Statement**

This Class B digital apparatus meets the requirements of the Canadian Interference-Causing Equipment Regulations.

### **Avis de conformité à la réglementation d'Industrie Canada**

Cet appareil numérique de la classe B respecte toutes les exigences du Règlement sur le matériel brouilleur du Canada.

### **Deutsche EMV-Direktive (electromagnetische Verträglichkeit)**

Dieses Gerät ist berechtigt in Übereinstimmung mit dem deutschen EMVG vom 9.Nov.92 das EG-Konformitätszeichen zu führen.

Der Aussteller der Konformitätserklärung ist die IBM UK, Greenock.

Dieses Gerät erfüllt die Bedingungen der EN 55022 Klasse B.

### **European Union - Emission Directive**

This product is in conformity with the protection requirements of EU Council Directive 89/366/ECC on the approximation of the laws of the Member States relating to electromagnetic compatibility.

IBM can not accept responsibility for any failure to satisfy the protection requirements resulting from a non-recommended modification of the product, including the fitting of non-IBM option cards.

This product has been tested and found to comply with the limits for Class B Information Technology Equipment according to CISPR 22 / European Standard EN 55022. The limits for Class B equipment were derived for typical residential environments to provide reasonable protection against interference with licensed communication devices.

### **Union Européenne - Directive Conformité électromagnétique**

Ce produit est conforme aux exigences de protection de la Directive 89/336/EEC du Conseil de l'UE sur le rapprochement des lois des États membres en matière de compatibilité électromagnétique.

IBM ne peut accepter aucune responsabilité pour le manquement aux exigences de protection résultant d'une modification non recommandée du produit, y compris l'installation de cartes autres que les cartes IBM.

Ce produit a été testé et il satisfait les conditions de l'équipement informatique de Classe B en vertu de CISPR22 / Standard européen EN 55022. Les conditions pour l'équipement de Classe B ont été définies en fonction d'un contexte résidentiel ordinaire afin de fournir une protection raisonnable contre l'interférence d'appareils de communication autorisés.

### **Unione Europea - Direttiva EMC (Conformidad electromagnética)**

Este producto satisface los requisitos de protección del Consejo de la UE, Directiva 89/336/CEE en lo que a la legislación de los Estados Miembros sobre compatibilidad electromagnética se refiere.

IBM no puede aceptar responsabilidad alguna si este producto deja de satisfacer dichos requisitos de protección como resultado de una modificación no recomendada del producto, incluyendo el ajuste de tarjetas de opción que no sean IBM.

Este producto ha sido probado y satisface los límites para Equipos Informáticos Clase B de conformidad con el Estándar CISPR22 y el Estándar Europeo EN 55022. Los límites para los equipos de Clase B se han establecido para entornos residenciales típicos a fin de proporcionar una protección razonable contra las interferencias con dispositivos de comunicación licenciados.

この装置は、情報処理装置等電波障害自主規制協議会（VCCI）の基準に基づく第二種情報技術装置です。この装置は、家庭環境で使用することを目的としていますが、この装置がラジオやテレビジョン受信機に近接して使用されると、受信障害を引き起こすことがあります。取扱説明書に従って正しい取り扱いをして下さい。

### **Union Eurpea - Normativa EMC**

Questo prodotto è conforme alle normative di protezione ai sensi della Direttiva del Consiglio dell'Unione Europea 89/336/CEE sull'armonizzazione legislativa degli stati membri in materia di compatibilità elettromagnetica.

IBM non accetta responsabilità alcuna per la mancata conformità alle normative di protezione dovuta a modifiche non consigliate al prodotto, compresa l'installazione di schede e componenti di marca diversa da IBM.

Le prove effettuate sul presente prodotto hanno accertato che esso rientra nei limiti stabiliti per le apparecchiature di informatica Classe B ai sensi del CISPR 22 / Norma Europea EN 55022. I limiti delle apparecchiature della Classe B sono stati stabiliti al fine di fornire ragionevole protezione da interferenze mediante dispositivi di comunicazione in concessione in ambienti residenziali tipici.



Part Number: 30F6915

Printed in U.S.A.

30F6915

